

CHENGLIAN

产品特性 Product Features



- ✓
- ✓
- ✓
- ✓
- ✓
- ✓
- ✓
- ✓

应用领域 Application area

参考标准 Reference standard

产品描述 Product Description

● 安装方式: Installation method:

警示

- 使用安装螺丝 M3*6mm.
- 深入外壳螺丝深度 MAX 3mm.
- 详见右图

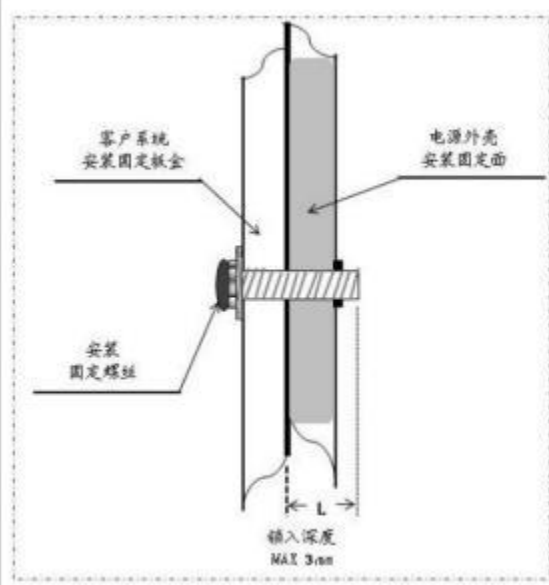

● 产品安装、使用说明:

● 运输、储存: Transportation and storage: