

CHENGLIAN

产品特性 Product Features

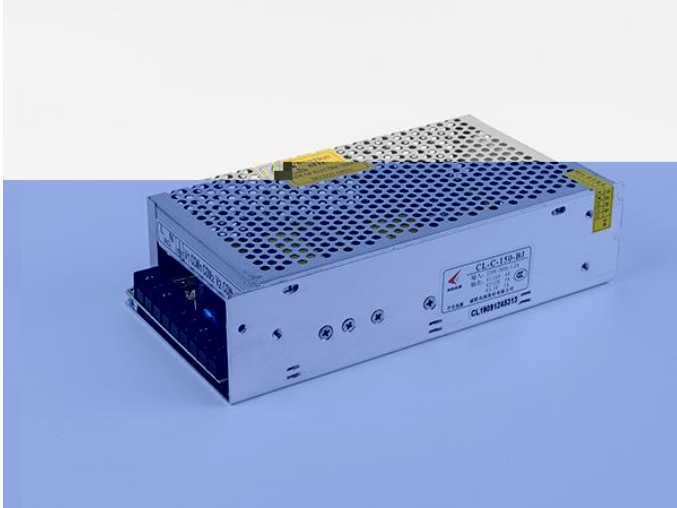

- ✓
- ✓
- ✓
- ✓
- ✓
- ✓
- ✓
- ✓
- ✓

应用领域 Application Area

参考标准 Reference standard

产品描述 Product Description

| | | | | |
|--|--|---|--|--|
| | | | | |
| | | | | |
| | | | | |
| | | | | |
| | | × × | | |
| | | <input checked="" type="checkbox"/> <input type="checkbox"/> | | |
| | | <input type="checkbox"/> <input type="checkbox"/> <input type="checkbox"/>) <input type="checkbox"/> | | |
| | | | | |

● 静态特性曲线

负载VS输入电压



● 输出负载与温度曲线

负载VS环境温度

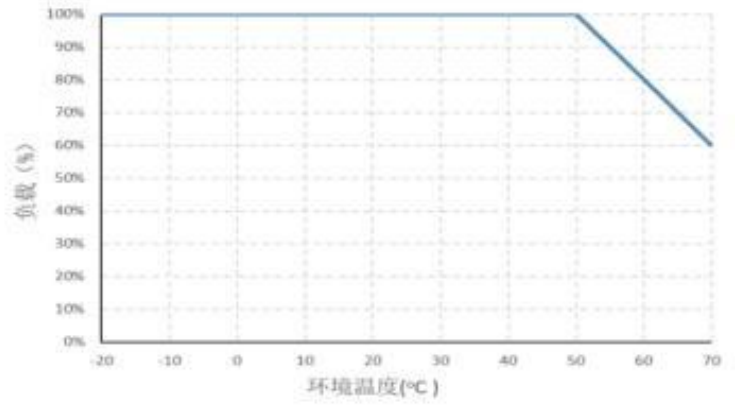

● 机构尺寸

Organizational size

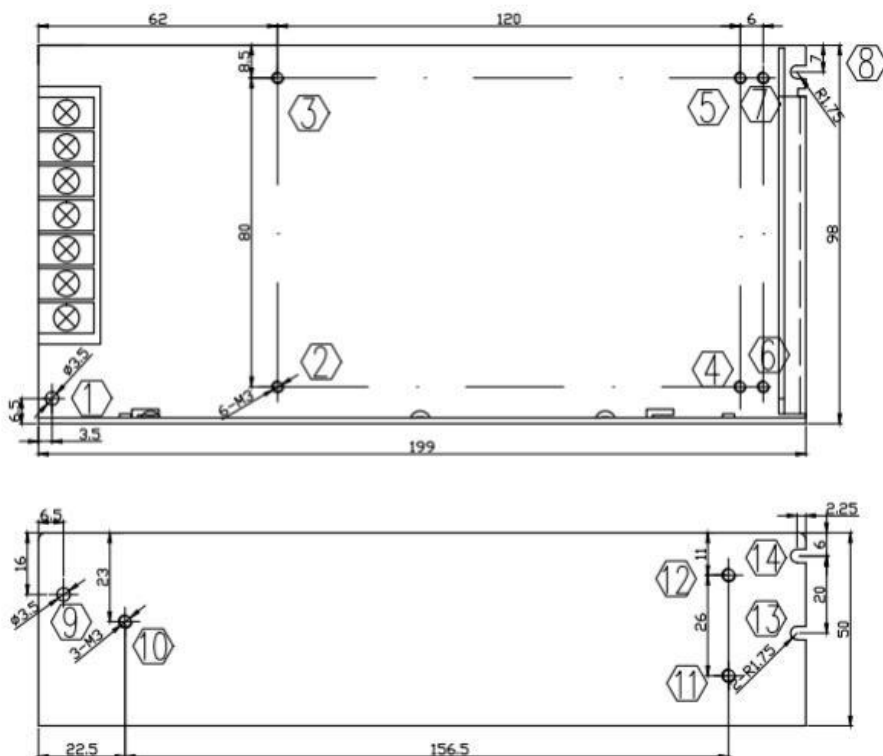

安装方式:

Installation method

警示

- 使用安装螺丝 M3*6mm.
- 深入外壳螺丝深度 MAX 3mm.
- 详见右图

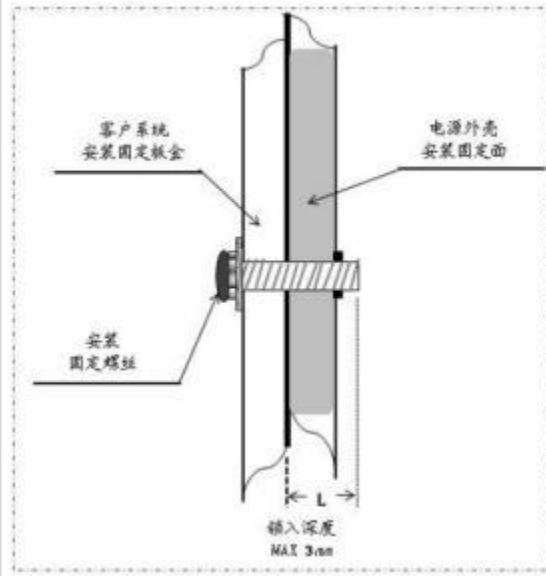

产品安装 使用说明:

Installation and use instructions

运输、储存:

Transportation and storage: