

# CHENGLIAN

## 产品特性 Product Features

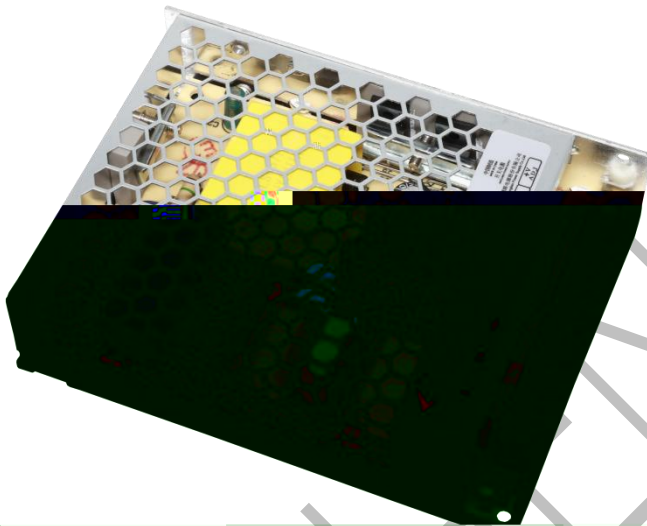

- ✓
- ✓
- ✓
- ✓
- ✓
- ✓
- ✓
- ✓

## 应用领域 Application area

## 参考标准 Reference standard

## 产品描述 Product Description



# 产品命名

Product Naming

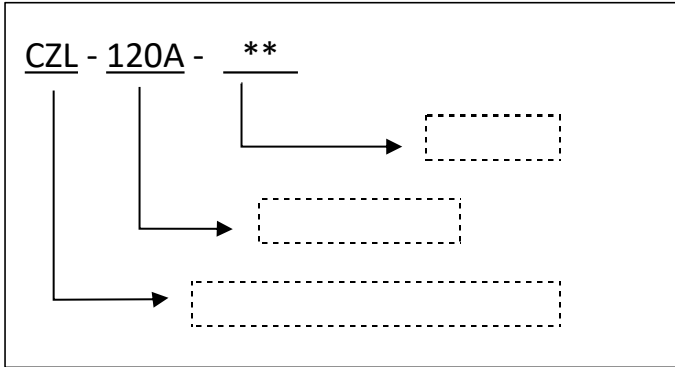



# 电气参数

Electrical parameters

	CZL-120A-12	CZL-120A-24	CZL-120A-36	CZL-120A-48
	176~264VAC			
	230VAC/1.4A			
	86%	88%	89%	88%
	47~63HZ			
	<1mA/240VAC			
	50A/230VAC			
	12V	24V	36V	48V
	10A	5A	3.3A	2.5A
	120W	120W	118.8W	120W
	± 5%	± 5%	± 3%	± 3%
	150mVp-p	200mVp-p	200mVp-p	200mVp-p
	2000ms	50ms/230VAC	100%	
	20ms/230VAC	100%		
	± 0.5%	± 0.5%	± 0.5%	± 0.5%
	± 0.5%	± 0.5%	± 0.5%	± 0.5%
	± 1.0%	± 1.0%	± 1.0%	± 1.0%
	-30~70	25		
	-30~80	25		
	10~500Hz,	2G,	10min, X,Y,Z	6
	20G,	11ms, X,Y,Z	3	
	2000mtrs	2000m	100m	0.6 )
	EN55024	EN61000-4-2,3,4,5,6,8,11		
	GB17625.1	EN61000-3-2,-3		
EMC	EN55022			
	GB4943/UL1012			
	--	I/P-O/P:1.5Kvac/5mA	---	I/P-CASE:1.5Kvac/5mA
		O/P-CASE:0.5Kvac/5mA		1min
	I/P-O/P	10M ohms	I/P-Case	10M ohms
			O/P-Case	10M ohms
	13.5-16.5	27-30	39-42	52-55
	110~165%rated			
	/			

MTBF	25	100000Hrs	MIL-217	Method	
	129*97*30	* *			
	0.32Kg/	40 /	13.5KG/		
	<input checked="" type="checkbox"/>	<input type="checkbox"/>			
	<input type="checkbox"/>	<input type="checkbox"/>	<input type="checkbox"/>	-40 ) <input type="checkbox"/>	
*		230VAC		25	
*		30%		100W	
	130W				
*		20MHz			
	12mm	10uF		0.1uF	

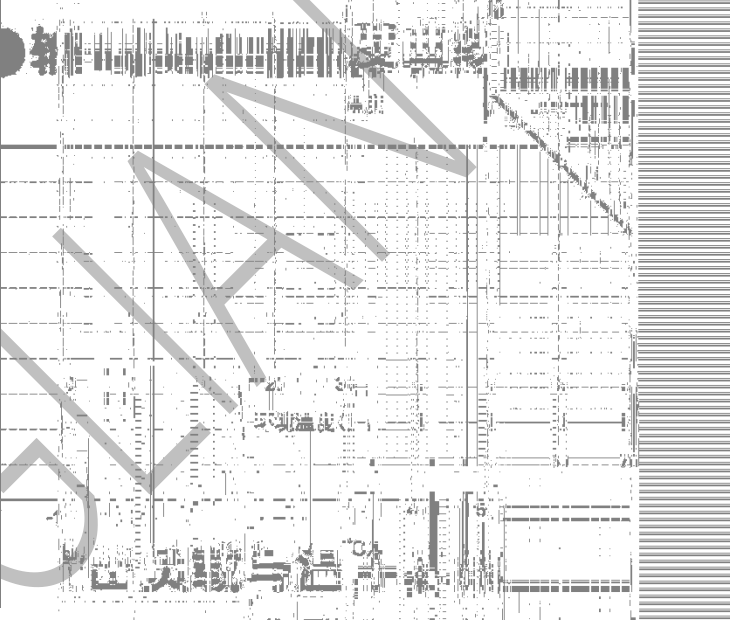
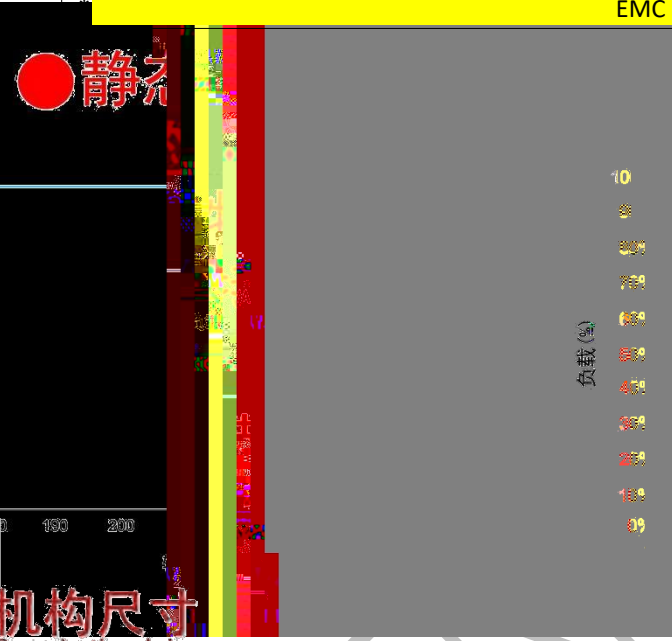
EMC



CHEM

 **安装方式:**  
Installation method:

 **产品安装、使用说明:**  
Installation and User Guide:

 **运输、储存:**  
Transportation and storage:

CHENGLIAO